

# PHYSICS Stage 3A/3B

Semester 2 Examination, 2011

Willetton Senior

High School



Name: \_\_\_\_\_

Teacher: \_\_\_\_\_

### *Time allowed for this paper*

Reading time before commencing work: Ten minutes

Working time for paper: Three hours

### *Material required/recommended for this paper*

#### **To be provided by the supervisor**

This Question/Answer Booklet

Physics: Formulae, Constants and Data Sheet (inside front cover of this Question/Answer Booklet)

#### **To be provided by the candidate**

Standard Items: Pens, pencil, eraser, correction fluid, ruler, highlighter

Special Items: non-programmable calculators satisfying the conditions set by the Curriculum Council for this course, drawing templates, drawing compass and a protractor

### *Important note to candidates*

No other items may be taken into the examination room. It is **your** responsibility to ensure that you do not have any unauthorised notes or other items of a non-personal nature in the examination room. If you have any unauthorised material with you, hand it to the supervisor **before** reading any further.

***Structure of this paper***

Section	Number of questions available	Number of questions to be answered	Suggested working time (minutes)	Marks available	Percentage of exam
Section One: Short response	13	13	50	54	30
Section Two: Problem-solving	8	8	90	90	50
Section Three: Comprehension	2	2	40	36	20
			<b>180</b>	<b>180</b>	<b>100</b>

***Instructions to candidates***

1. The rules for the conduct of Western Australian external examinations are detailed in the *Year 12 Information Handbook 2011*. Sitting this examination implies that you agree to abide by these rules.
2. Write answers in this Question/Answer Booklet.
3. You must be careful to confine your responses to the specific questions asked and to follow any instructions that are specific to a particular question.
4. Working or reasoning should be clearly shown when calculating or estimating answers.
5. Spare pages are included at the end of this booklet. They can be used for planning your responses and/or as additional space if required to continue an answer.
  - Planning: If you use the spare pages for planning, indicate this clearly at the top of the page.
  - Continuing an answer: If you need to use the space to continue an answer, indicate in the original answer space where the answer is continued, i.e. give the page number. Fill in the number of the question(s) that you are continuing to answer at the top of the page.

**SEE NEXT PAGE**

**SECTION ONE: Short Response****54 marks (30%)**

This section has 13 questions. Answer **ALL** questions. Write your answers in the spaces provided. Suggested working time for this section is **54 minutes**.

**Question 1****(2 marks)**

The diagram below shows a boat taking shelter from large waves behind a high stone barrier. Explain why the boat is still at risk of damage from the waves.

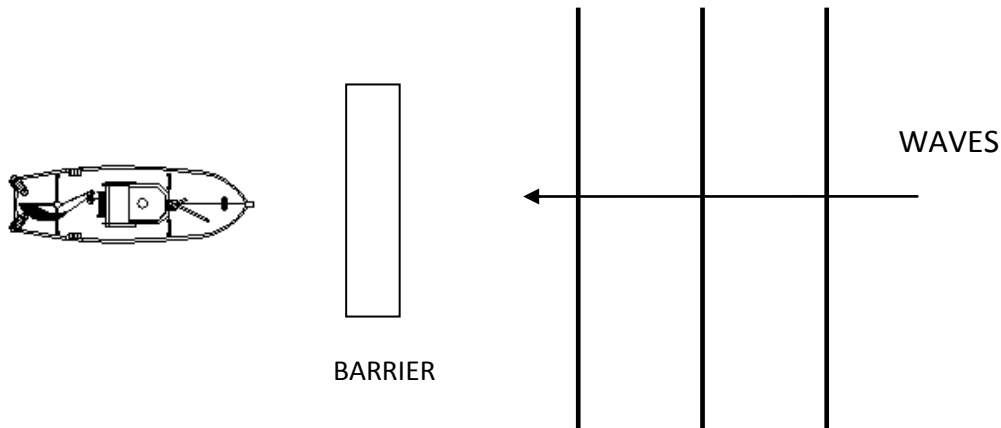
**Question 2****(4 marks)**

Hamish, who has a mass of 65.0 kg, is walking across a high wire suspended between two buildings. The wire makes an angle of  $10^\circ$  to the horizontal where it is attached at either end. Find the tension in the wire.

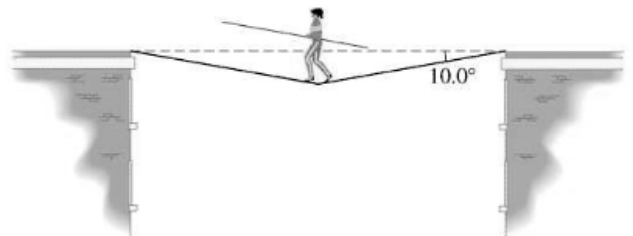
**SEE NEXT PAGE**

Question 3

(4 marks)

The table below shows the 6 types of sub-atomic particles known as quarks and their properties:

NAME	SYMBOL	Charge (Q)	Baryon Number (B)	Strangeness (S)	Charm (c)	Bottomness (b)	Topness (t)
<i>Up</i>	u	$+\frac{2}{3}e$	$\frac{1}{3}$	0	0	0	0
<i>Down</i>	d	$-\frac{1}{3}e$	$\frac{1}{3}$	0	0	0	0
<i>Strange</i>	s	$-\frac{1}{3}e$	$\frac{1}{3}$	-1	0	0	0
<i>Charmed</i>	c	$+\frac{2}{3}e$	$\frac{1}{3}$	0	+1	0	0
<i>Bottom</i>	b	$-\frac{1}{3}e$	$\frac{1}{3}$	0	0	-1	0
<i>Top</i>	t	$+\frac{2}{3}e$	$\frac{1}{3}$	0	0	0	+1

(a) Use the information in the table to complete the table below, to show the composition of the *Pion-minus* meson and the *Kaon-plus* meson.

NAME	SYMBOL	B	S	c	b	t	Quarks
<i>Pion-plus</i>	$\pi^+$	0	0	0	0	0	$u\bar{d}$
<i>Pion-minus</i>	$\pi^-$	0	0	0	0	0	
<i>Kaon-plus</i>	$K^+$	0	+1	0	0	0	

(2 marks)

(b) The constituents of a proton can be represented by:  $uud$  and an antiproton by  $\bar{u}\bar{u}\bar{d}$ . Use this notation to show the constituents of the following:

i. Neutron: \_\_\_\_\_

ii. Antineutron: \_\_\_\_\_

(2 marks)

**Question 4****(3 marks)**

Diagram 1 below shows some of the energy levels (measured in electron-volts) of the hydrogen atom. Diagram 2 is a representation of part of the visible spectrum of atomic hydrogen (not to scale).

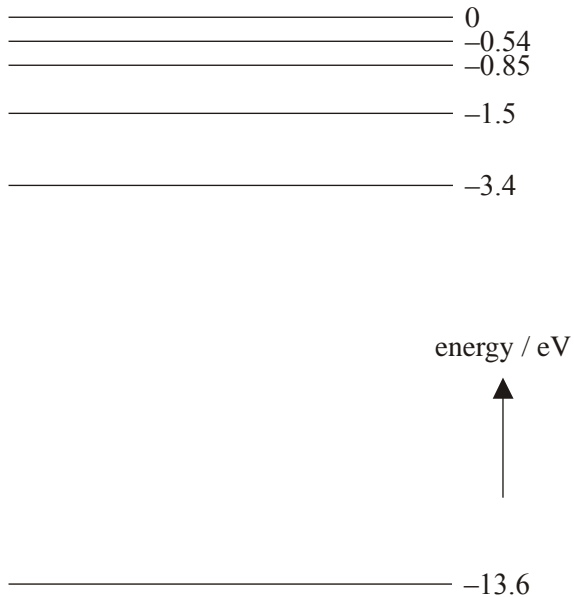
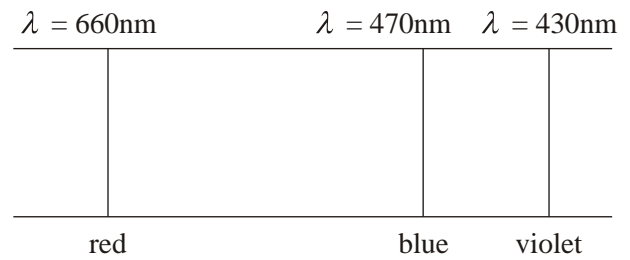
**Diagram 1****Diagram 2**

On diagram 1, show with arrows the electron transitions that give rise to the red, blue and violet lines in the visible spectrum of hydrogen, Label the arrows as **R**, **B** and **V** respectively.

**Question 5****(4 marks)**

The “observable edge” of the universe is about 12 billion light years away from us.

- (a) Given  $v = H_0 d$  how fast, relative to us is a galaxy at this distance travelling?

**(2 marks)**

(Take Hubble’s Constant to be 160 km/sec per million light-years)

- (b) Explain why “Hubble’s Law” is evidence that the universe is expanding.

**(2 marks)**

**Question 6****(5 marks)**

The diagram below illustrates some equipotential lines between two charged parallel metal plates.

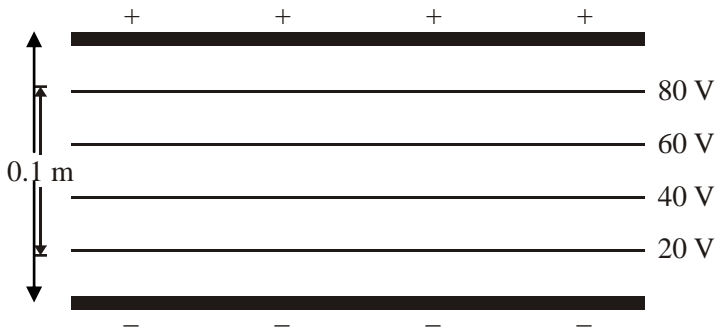

(a) Calculate the electric field strength between the plates. (1 mark)

(b) On the diagram, sketch the electric field distribution between the plates. (1 mark)

(c) An electron is accelerated from rest between the 2 plates. Find its final velocity. (3 marks)

**Question 7****(3 marks)**

The diagram below shows a human hand exerting a force on the grips of a pair of tongs.

(a) How does the force that could be applied at the **load** compare to the force applied by the hand? Circle the correct word. (1 mark)

**GREATER**      **LESS**      **SAME**

(b) Explain why you chose the answer above. (2 marks)



**Question 8**

**(5 marks)**

The mass of Pluto was not known until it was discovered that Pluto had a moon. Explain why this fact helped scientists determine Pluto's mass. Be sure to state what observations the scientists needed to make and include appropriate equations in your explanation.

**Question 9**

**(6 marks)**

The diagrams below show different arrangements of current carrying conductors. Indicate clearly the shape and direction of the magnetic fields in each situation. In (b) be sure to indicate the shape of the field on the card.

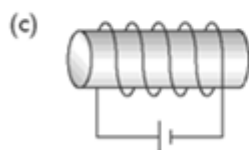
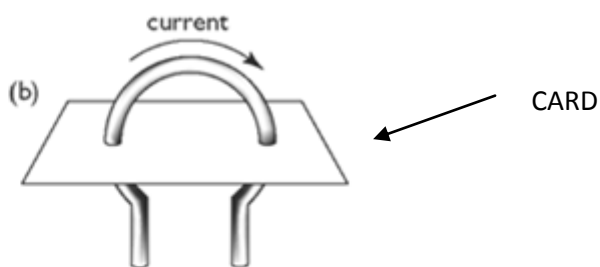
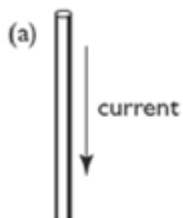



## Question 10

(6 marks)

Sophie is traveling on a futuristic bus that is travelling to the right at a constant speed of 90% of the speed of light. The bus travels straight past Eloise who was waiting for another bus. At the instant that the centre of the bus passes Eloise, she notices 2 lightning strikes at either end of the bus. Eloise observes that the 2 flashes of light occurred simultaneously (at the same time).

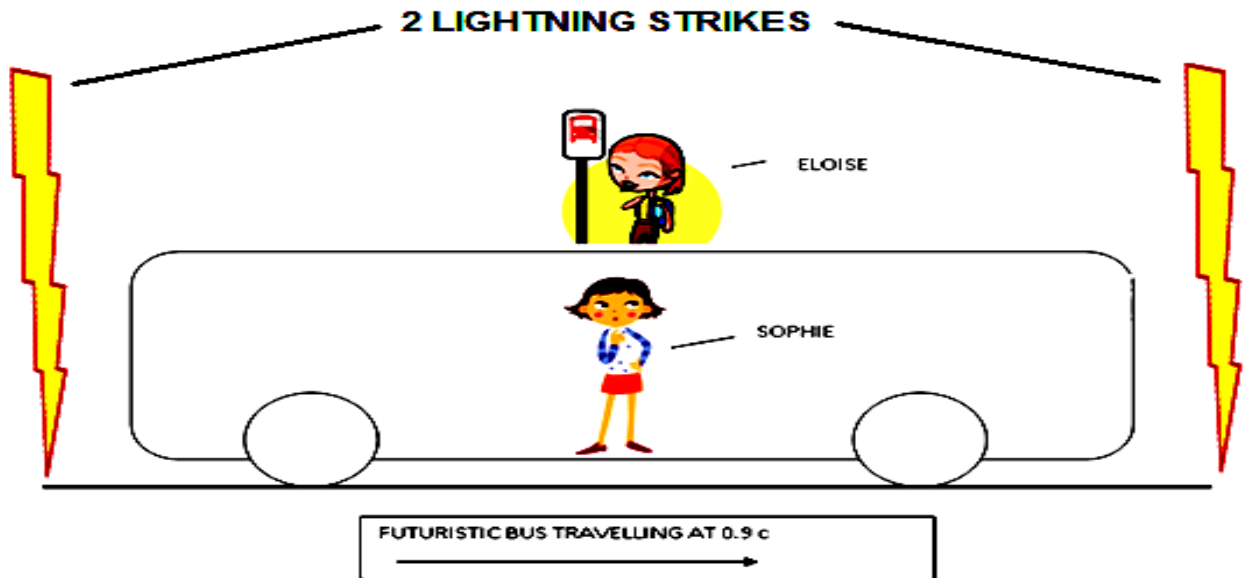

Eloise thinks that Sophie will see the lightning strike closest to the front of the bus first as the bus is “travelling to meet” the light from the front strike. In fact Sophie **does** observe the front strike first, but concludes that the front strike happened before the strike at the back of the bus.

- a) Is one girl’s interpretation of the events more correct than the other’s? Explain carefully by making reference to Einstein’s Theory of Special Relativity. (3 marks)

- b) How does Sophie explain that the two flashes of light reach Eloise simultaneously? (3 marks)

SEE NEXT PAGE

**Question 11**

**(4 marks)**

A white wooden car is released and allowed to roll down a slope as shown below. The slope is made of aluminium and the car contains a small 50 gram lead mass.

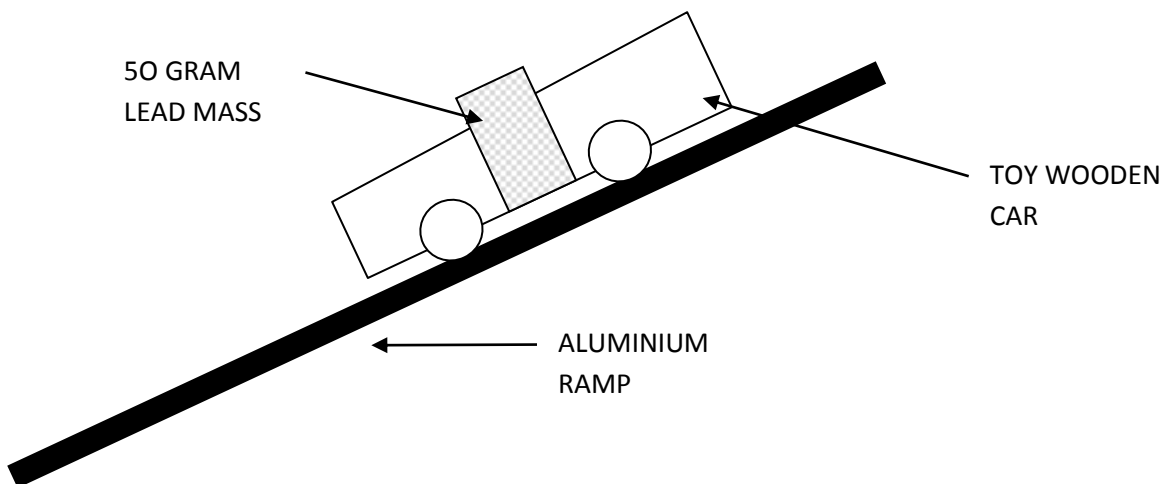

At the same time a similar grey car is released on an identical slope. This car contains a 150 gram steel magnet.

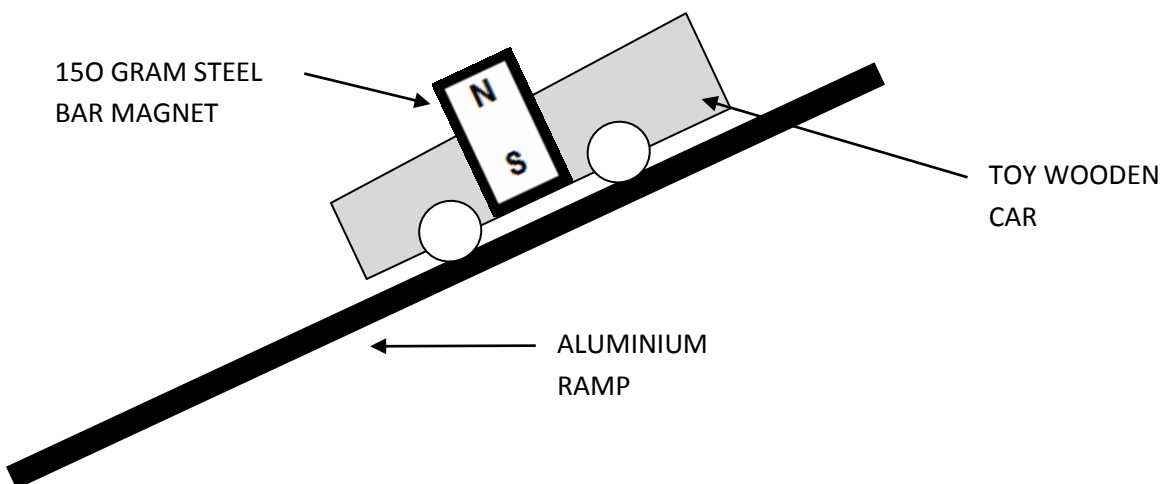

Which car will reach the bottom of its ramp first? Explain using appropriate Physics principles. **You should ignore the effects of friction.**

## Question 12

(5 marks)

Graph 1 below shows how displacement ( $d$ ) of a travelling (progressive) wave varies with time ( $t$ ).  
Graph 2 shows how displacement ( $d$ ) of the same wave varies with distance ( $x$ ).

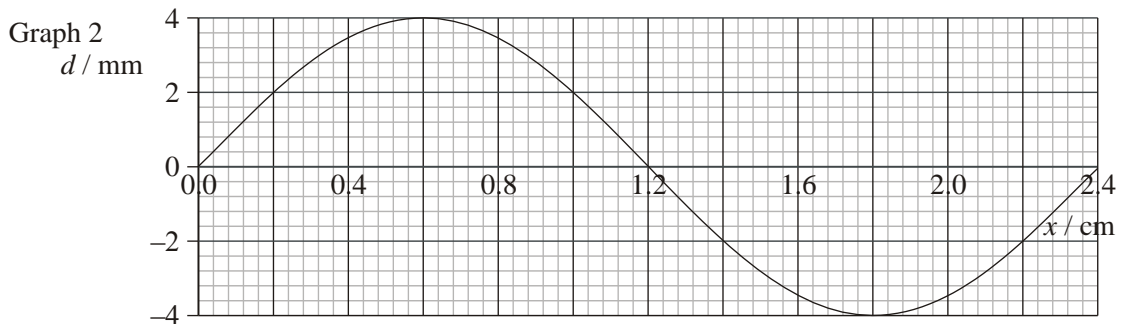
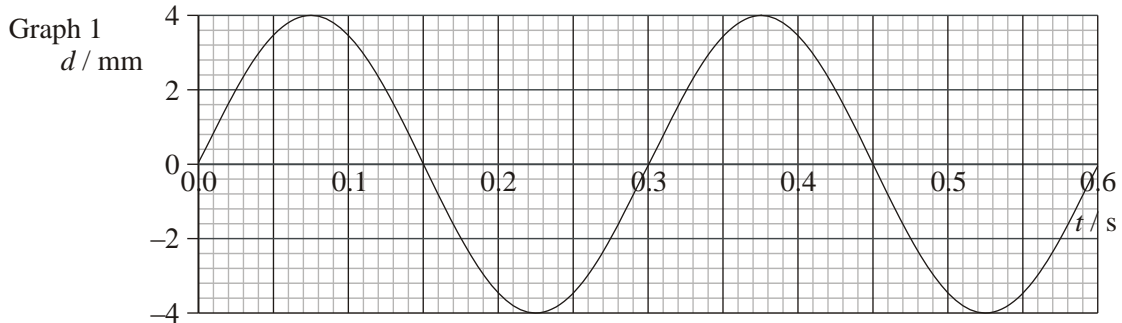

Use the information from the graphs to determine the following properties of the wave?

- (a) Amplitude: \_\_\_\_\_
- (b) Period: \_\_\_\_\_
- (c) Frequency: \_\_\_\_\_
- (d) Wavelength: \_\_\_\_\_
- (e) Velocity: \_\_\_\_\_

SEE NEXT PAGE

**Question 13****(3 marks)**

Two current carrying conductors are shown in the diagram below.

(a) Sketch the resultant magnetic field and **clearly label** any areas of high or low flux density.  
(2 marks)

(b) Is there any force between the two conductors? Circle the correct answer below.  
(1 mark)

*There is no force*

*There is a force of attraction*

*There is a force of repulsion*



**End of Section One**

**SEE NEXT PAGE**

**SECTION TWO: Problem-solving****90 marks (50%)**

This section has **seven (7)** questions. Answer **ALL** questions. Write your answers in the spaces provided. Suggested working time for this section is **90 minutes**.

**Question 14****(12 marks)**

Light can be produced by exciting electrons within atoms.

- (a) Following excitation, what happens next in order to produce light?

(3 marks)

- (b) Explain by calculating the relevant quantities, whether the excitation required to produce visible light could be achieved by bombarding an atom with electrons that have been accelerated through a potential difference of 240V.

(4 marks)

- (c) The diagram below shows the absorption spectra of the light emitted from the left and right sides of the Sun as viewed from Earth. **Note:** 1 Angstrom =  $10^{-10}$  m.

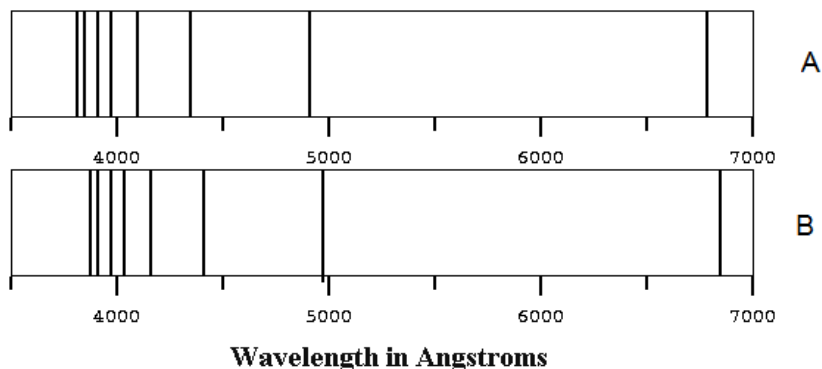
**SEE NEXT PAGE**

Scientists use the information in the two spectra as evidence that the Sun is spinning on its axis.

- i. Which spectrum, **A** or **B** shows light that is emitted from the receding side of the Sun?

(1 mark)

- ii. Explain how the lines in the spectra show that one side of the Sun is spinning towards us (approaching), while the other side is spinning away from us (receding).

(2 marks)

- (d) Explain briefly how a line absorption spectrum is formed.

(2 marks)

Question 15

(13 marks)

The diagrams below show a simple electric generator which can convert mechanical energy into electrical energy. A light metal rod, CD, is loaded with a mass  $M$  (diagram 1) and is able to slide downward while making contact with two long vertical metal rails PQ and RS. The rods are connected at the bottom by a resistor  $R$ , and the whole device is in a uniform magnetic field  $B$  perpendicular to the page. (Diagram 1)

When the loaded rod is released from rest, it falls downwards and as a result an electric current,  $I$ , flows around the circuit. The rod speeds up initially before reaching a constant downward speed. (Diagram 2)

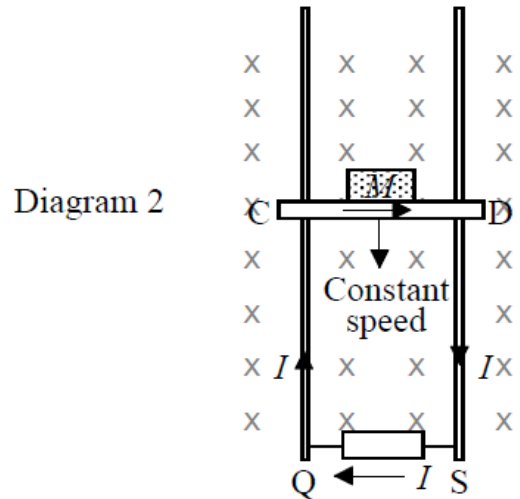
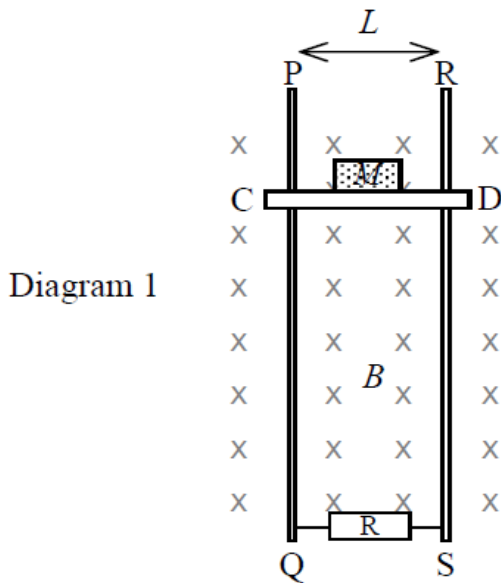

(a) Show on diagrams below, the force(s) acting on the loaded rod just as it is released and when it is falling with a constant speed. Show the forces as **labeled arrows**.

i. Just as it is released

ii. During its fall at constant speed

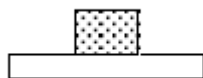

(4 marks)

(b) Explain why the rod accelerates initially and then reaches a constant speed.

(3 marks)

- (c) Derive an expression for the current  $I$  flowing through the conductor CD, in terms of  $L$ ,  $B$ ,  $M$  and  $g$ , while the rod is falling at a constant speed (Diagram 2).

**Note:**  $g$  is the acceleration due to gravity ( $9.80 \text{ ms}^{-2}$ )

(3 marks)

- (d) Using your answer to (c) above and Faraday's Law of Induction:  $emf = BvL$ , show that the constant velocity attained by the loaded rod CD is:

$$V = \frac{MgR}{B^2 L^2}$$

(3 marks)



**Question 16****(14 marks)**

A stuntman in a Mission Impossible film needs to jump from a helicopter travelling at a constant  $65 \text{ ms}^{-1}$  into a car traveling at  $25 \text{ ms}^{-1}$  in the same direction. He will drop from a point 35 m above the passenger seat of the car, which he will land in.

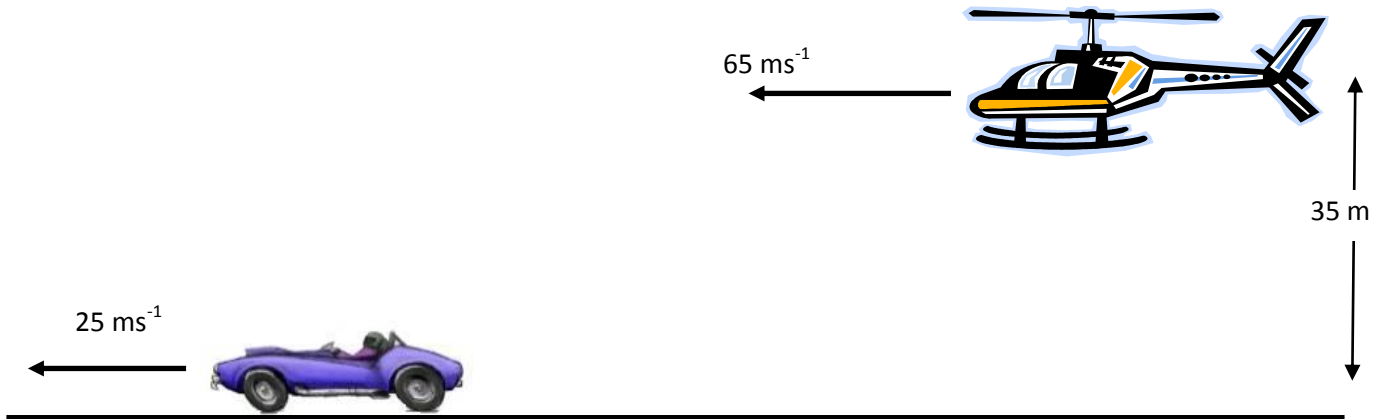

(a) How long does the stuntman take to fall from the helicopter to the car?

(2 marks)

(b) At what distance behind the car should the stuntman make his jump in order to land in the car?

(2 marks)

(c) At the instant shown in the diagram, the helicopter is 477 m behind the car. How long should the stuntman wait before he makes his jump? (4 marks)

(d) What is the velocity of the stuntman, relative to the car when he lands in the car? (4 marks)

(e) If the helicopter continues on the same path, where is the helicopter when the stuntman lands in the car? (2 marks)

**SEE NEXT PAGE**

**Question 17****(13 marks)**

A farmer decides to install some solar panels on his property. The site he has chosen is 550 m from his house. The solar system is rated at 4.2 kW and has an output voltage 48 Volts DC when exposed to full summer sun.

He also needs to install an “inverter”, this is an electronic device that converts the 48 V DC voltage to AC and also steps it up to 240 V. The particular inverter used is rated to convert 48 V DC to 240 V AC. This is essential as all of the appliances in the house run on 240 V AC.

The connecting wires from the solar system to his house have a total resistance of 0.30 ohm.

The farmer is not sure whether to install the inverter at the solar panels (configuration A), at the house (configuration B) or if it doesn't matter.

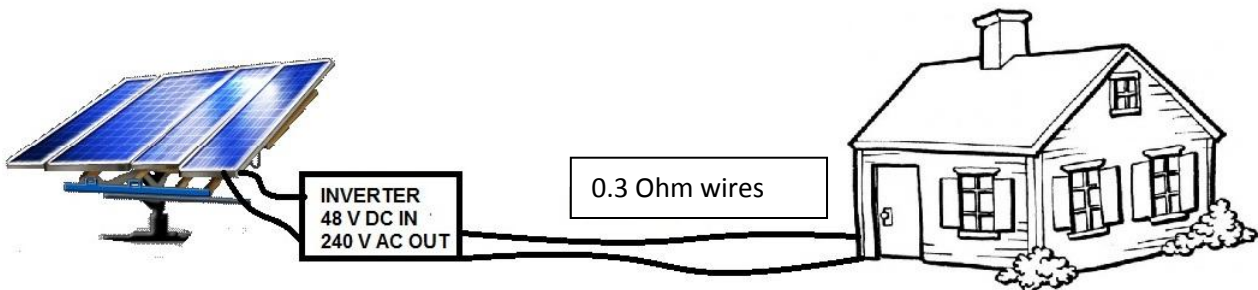

**CONFIGURATION A (INVERTER AT SOLAR PANELS)**

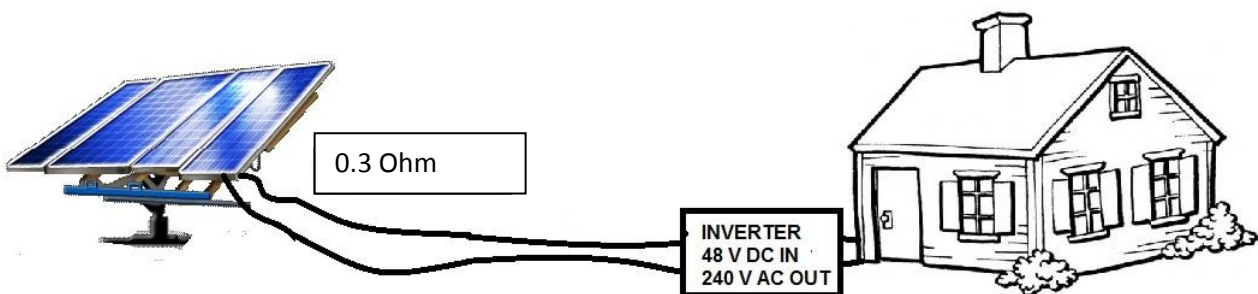

**CONFIGURATION B (INVERTER AT THE HOUSE)**

(a) What current is flowing in the 3.0 Ohm transmission wires for each configuration?

**Configuration A:**

**Configuration B:**

**(4 marks)****SEE NEXT PAGE**

(b) What power is lost in the 0.30 Ohm transmission wires for each configuration?

**Configuration A:**

**Configuration B:**

(4 marks)

(c) By comparing the percentage efficiencies of the two configurations, make a recommendation to the farmer on which one to use.

(5 marks)

**SEE NEXT PAGE**

## Question 18

(10 marks)

Louise is experimenting with sound in the lab. The diagram below shows a loudspeaker which sends a note of constant frequency towards a vertical metal sheet. As Louise moves the microphone between the loudspeaker and the metal sheet, the reading on sound meter changes several times between maximum and minimum values.

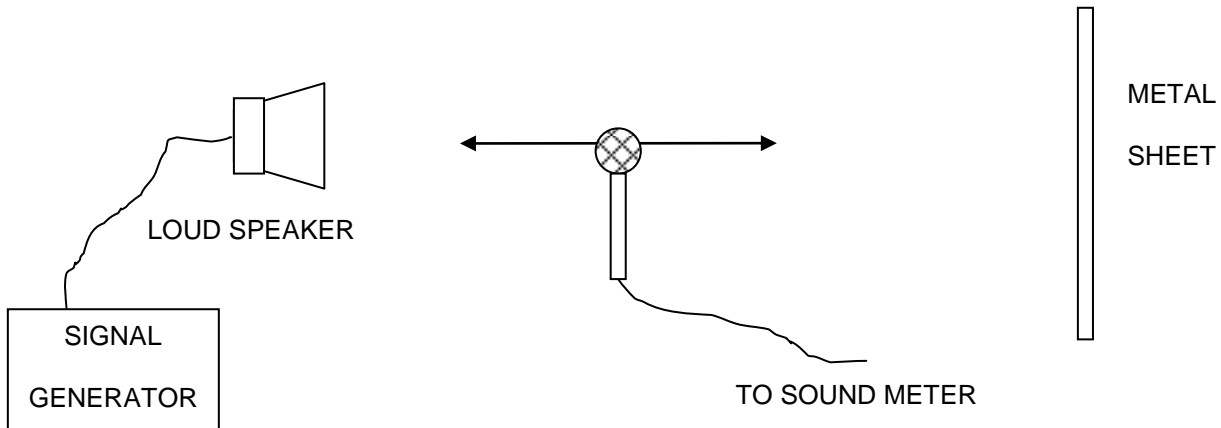

(a) Why did the reading on the sound meter change in the way described?

(3 marks)

(b) For one trial, Louise finds that the distance between two maximum readings is 14.5 cm. What frequency was the speaker emitting during this trial?

(3 marks)

(c) If Louise was to double the frequency supplied in part (b), what would be the distance between two successive points of minimum loudness?

(2 marks)

(d) Louise noticed that the points of minimum loudness were not as loud closer to the metal plate than they were near the speaker. Explain this observation.

(2 marks)

SEE NEXT PAGE

Question 19

(7 marks)

An engineering company is experimenting with a new type of transportation. It consists of a 365 kg aluminium glider that rests on two strong rails that provide an 825 Amp current that flows through the wings of the glider. A strong magnetic field in the region of the glider causes it to be propelled forward. The rails are 23.5 m apart.

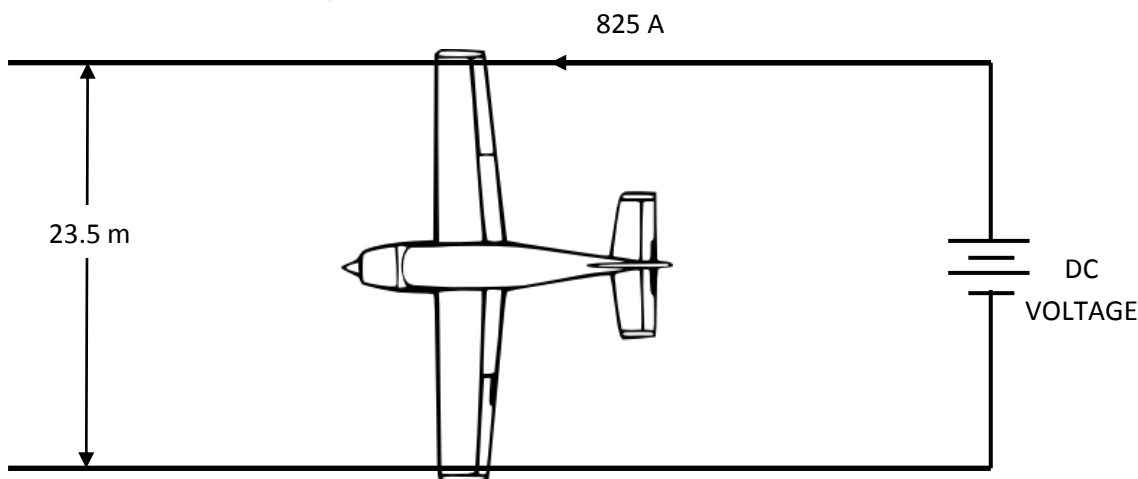

The magnetic field is produced by powerful electromagnets.

- (a) Show the direction of the field on the diagram as dots (out of the page) or crosses (into the page) (1 mark)
- (b) Find the intensity of the magnetic field necessary to propel the glider forward with an acceleration of  $2.6 \text{ ms}^{-2}$ . You may ignore the effects of friction.

(4 marks)

- (c) A scientist is monitoring the current flowing during the experiment and notices that it dropped as the glider gained speed. Explain his observation.

(2 marks)

**Question 20****(10 marks)**

The diagram to the right shows a 25.5 kg traffic light suspended from the end of a 15.0 kg, 7.50 m uniform aluminium pole.

- (a) Draw a free body diagram of the pole (AB), showing all forces acting on it.

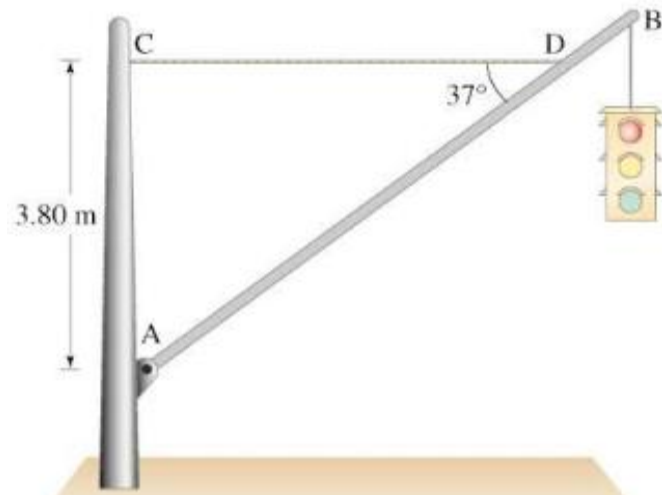

(2 marks)

- (b) Find the tension in the horizontal cable (CD).

(4 marks)

- (c) Find the size and direction of the reaction force exerted on the pole AB, by the hinge at A.

(4 marks)

**Question 21****(6 marks)**

Barnard's star is a red dwarf (ex-star) that has 17% of our Sun's mass and 15% of our Sun's diameter. Barnard's star still radiates heat (and light), but is much cooler than our own Sun.

For Barnard's star to have a planet with liquid water at its surface, the planet would need to be quite close to the star's surface. According to astronomers, a suitable distance would be 0.06 AU. Such a planet is said to be in the "Habitable Zone". Note one AU (astronomical unit) and is the distance between the Earth and our Sun.

- (a) Determine the time, in weeks, that it would take a planet in the habitable zone to orbit Barnard's Star.

(4 marks)

- (b) Barnard's star is in the constellation Ophiuchus. Given that light from this star takes 5.94 years to reach the Earth, find the distance to Barnard's Star in km.

(2 marks)



**Question 22****(5 marks)**

In the science fiction series Star Trek, Captain Kirk orders the starship Enterprise to travel from Earth on a rescue mission to Alpha Centauri (4.2 light-years away). Due to battle damage, the fastest speed that the Enterprise can travel at is just below the speed of light. The crew includes twins, and while one of two identical twins is on the mission to Alpha Centauri the other remains on Earth.

- (a) The Enterprise can only manage a speed of  $0.98c$  ( $c$  = speed of light). At this speed, how long will the starship take to travel to Alpha Centauri and return as seen from Earth?

(1 mark)

- (b) The time dilation equation is

$$t_0 = t \sqrt{1 - \frac{v^2}{c^2}}$$

where  $t_0$  is the apparent time elapsed on the starship and  $t$  is the actual time taken for the trip. For the crew on board, what appears to be the time taken to travel to Alpha Centauri and return?  
(2 marks)

- (c) On the return to Earth the twins are no longer the same age, one is older. Which twin has aged more and by how much?  
(2 marks)

**End of Section Two**

**SEE NEXT PAGE**

**SECTION THREE: Comprehension and data analysis****36 marks (20%)**

This section contains **two (2)** questions. You must answer both questions. Write your answers in the spaces provided. Suggested working time for this section is **40 minutes**.

**Question 23****Stopping Distances****(18 marks)**

As part of a road-safety campaign, the braking distances of a car were measured. A driver in a particular car was instructed to travel along a straight road at a constant speed  $v$ . A signal was given to the driver to stop and he applied the brakes to bring the car to rest in as short a distance as possible. The total distance  $D$  travelled by the car after the signal was given was measured for corresponding values of  $v$ . A sketch graph of the results is shown below.

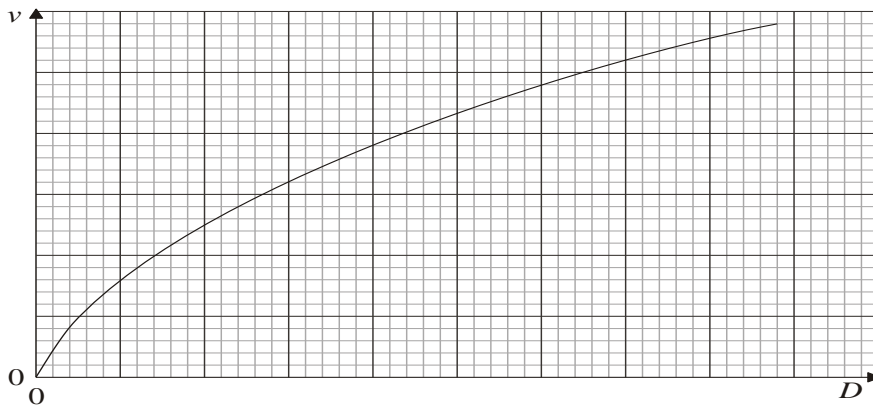

- (a) State why the sketch graph suggests that  $D$  and  $v$  are **not** related by an expression of the form

$$D = mv + c \quad \text{where } m \text{ and } c \text{ are constants.}$$

(2 marks)

It is suggested that  $D$  and  $v$  may be related by an expression of the form

$$D = av + bv^2 \quad \text{where } a \text{ and } b \text{ are constants.}$$

In order to test this suggestion, the data shown in the table below are used. The uncertainties in the measurements of  $D$  and  $v$  are not shown.

$v$ ( $\text{m s}^{-1}$ )	$D$ (m)	$D/v$ (.....)
10.0	14.0	1.40
13.5	22.7	1.68
18.0	36.9	2.05
22.5	52.9	.....
27.0	74.0	2.74
31.5	97.7	3.10

**SEE NEXT PAGE**

- (b) (i) In the table above, insert the unit for  $D/v$  into the space in the brackets. [1 mark]
- (ii) Calculate the value of  $D/v$ , for  $v = 22.5 \text{ m s}^{-1}$ , to an appropriate number of significant figures and insert in the space in the table above. [2 mark]
- (c) Data from the table are used to plot a graph of  $D/v$  ( $y$ -axis) against  $v$  ( $x$ -axis). Some of the data points are shown plotted below.

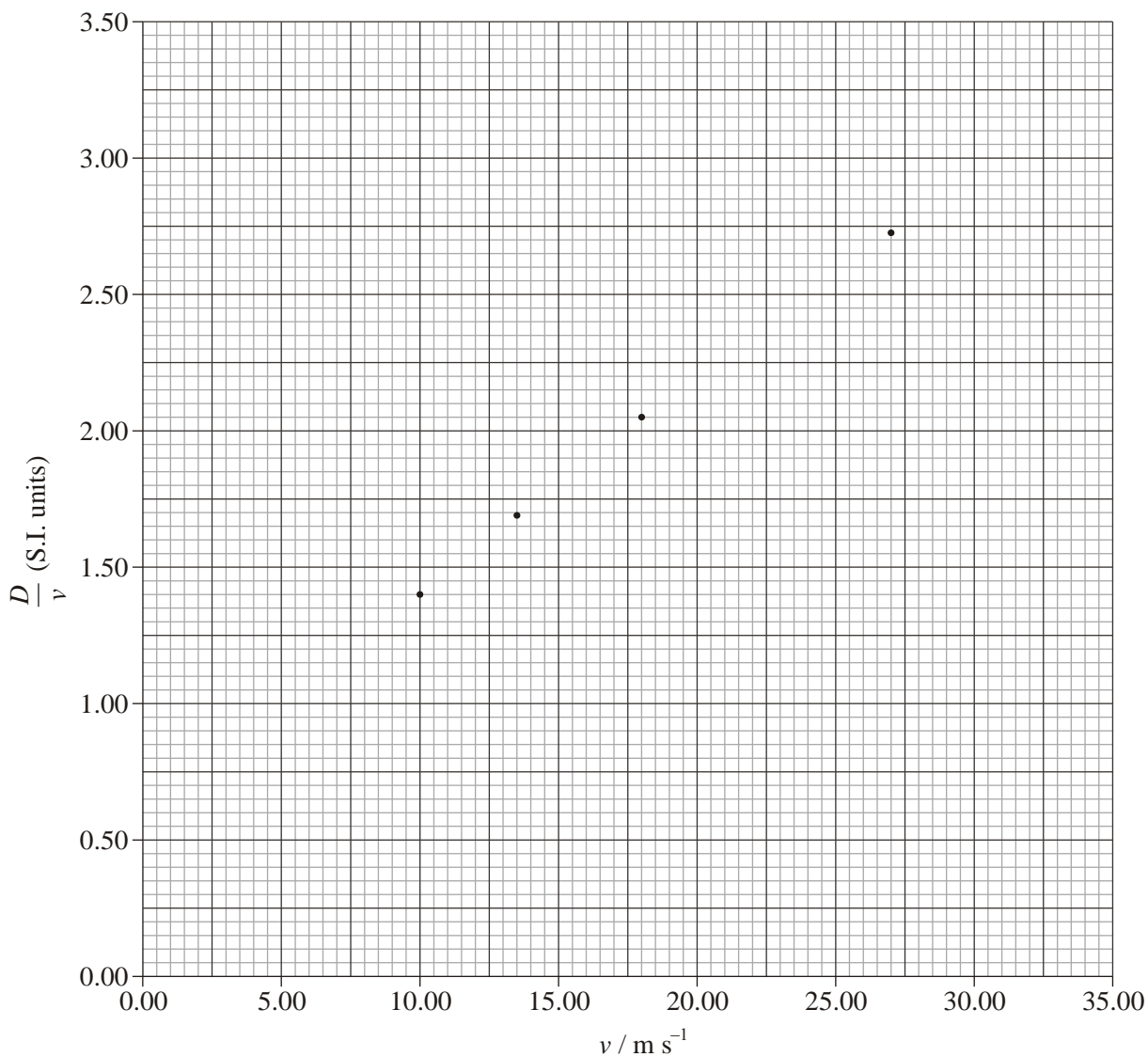

On the graph above,

- (i) plot the data points for speeds of  $22.5 \text{ m s}^{-1}$  and  $31.5 \text{ m s}^{-1}$ . (2 marks)
- (ii) draw the line of best fit for all the data points. (2 marks)

- (d) Use your graph in (c) to determine
- (i) the total stopping distance  $D$  for a speed of  $35 \text{ ms}^{-1}$ .  
(2 marks)
  - (ii) the intercept on the  $D/v$  axis.  
(2 marks)
  - (iii) the gradient of the line of best fit.  
(2 marks)
- (e) Using your answers to (d)(ii) and (d)(iii), deduce the equation for  $D$  in terms of  $v$ .
- $D =$
- (3 marks)

Question 24

WHAT IS THE UNIVERSE MADE OF?

(18 marks)

Adapted from: *Science News*, 23/04/2011, Vol. 179 Issue 9, p24-25 by Alexandra Witze

Read the article and then answer the questions that follow.

In ancient times, listing the ingredients of the universe was simple: earth, air, fire and water. Today, scientists know that naming all of that, plus everything else familiar in everyday life, leaves out 95 percent of the cosmos's contents'.

From the atoms that make up an astronomer, to the glass and steel of a telescope, to the hot plasma of the stars above -- all ordinary stuff accounts for less than 5 percent of the mass and energy in the universe. "All the visible world that we see around us is just the tip of the iceberg," says Joshua Frieman, an astrophysicist at the University of Chicago and the Fermi National Accelerator Laboratory in Batavia, Ill.

The rest is, quite literally, dark. Nearly one-quarter of the universe's composition is as-yet-unidentified material called dark matter. The remaining 70 percent or so is a mysterious entity known as *dark energy* that pervades all of space, pushing it apart at an ever-faster rate.

### A different matter

Dark matter made its debut in 1933, when Swiss astronomer Fritz Zwicky measured the velocities of galaxies in a group known as the Coma cluster and found them moving at different rates than expected. Some unseen and large amount of "dunkle Materie," he proposed in German, must exist, exerting its gravitational effects on the galaxies within the cluster.

Astronomer Vera Rubin confirmed dark matter's existence in the 1970s, after she and colleagues had measured the speeds of stars rotating around the centres of dozens of galaxies. She found that, counter intuitively, stars on the galaxies' outer fringes moved just as rapidly as those closer in - as if Pluto orbited the sun as quickly as Mercury. Rubin's work demonstrated that each galaxy must be embedded in some much larger gravitational scaffold.

The leading candidate for a dark matter particle is the vaguely named "weakly interacting massive particle," or WIMP. Such particles would be "weakly interacting" because they rarely affect ordinary matter, and "massive" because they must exceed the mass of most known particles, possibly weighing in at as much as 1,000 times the mass of the proton. But nobody has yet definitively detected a WIMP, despite decades of experiments designed to spot one.

### Mysterious forces

Spotting dark matter may prove to be easier than understanding dark energy, whose mysteries make scientists feel like mental wimps.

Albert Einstein unknowingly ushered dark energy onto the stage in 1917, while modifying his new equations of general relativity. Einstein wondered why gravity didn't make the universe contract in on itself, like a balloon with the air sucked out of it. In 1929, though, Edwin Hubble solved Einstein's problem by reporting that distant galaxies were flying away from each other. The universe, Hubble showed, was expanding. It had been zooming outward ever since the Big Bang gave birth to it. Something funny was going on, giving the cosmos a repulsive push. So in 1998 Michael Turner, a cosmologist at the University of Chicago, dubbed the thing "funny energy" at first, before settling on "dark energy."

**SEE NEXT PAGE**

- a) According to the article, all matter that we can observe makes up only 5% of the content of the Universe. What constitutes the other 95%? (2 marks)

---

---

---

---

---

- b) What observations did Fritz Zwicky make for him to theorise about the presence of “dunkle Materie” (translates to “Dark Matter” in English)? (2 marks)

---

---

---

---

---

- c) How did Vera Rubin confirm the existence of dark matter in 1970? (4 marks)

---

---

---

---

---

---

---

---

---

---

- d) Astronomers have theorized the existence of WIMPS (weakly interacting massive particles). Why do astronomers believe the particles must be massive? (2 marks)

---

---

---

---

---

- e) In 1917, Einstein pondered the fact that the Universe doesn't contract in on itself. Why do you think Einstein would have expected the Universe to contract? (2 marks)

---

---

---

---

---

- f) Why is the concept of "Dark Energy" necessary for our current understanding of astronomy? (2 marks)

---

---

---

---

---

- g) Our galaxy, the Milky Way contains approximately 300 billion stars. Assuming that our solar system is 26,000 light years from the centre of the galaxy, estimate the amount of mass that would need to be present at the centre of the galaxy (excluding the possibility of dark matter) for our sun to orbit the centre of the galaxy once every 225 million years. (4 marks)

**End of Questions**

**SEE NEXT PAGE**



Additional Working Space

---

---

---

---

---

---

---

---

---

---

---

---

---

---

---

---

---

---

---

---

---

---

---

---

---

---

---

---

---

---



